



Operation and Maintenance Manual for ST 100 Power Sources
P/N 5050-00557 REV. A 082006

This manual applies to:

Model	PACE Power Supply Number	System Part Number
ST 100	7008-0296-01	8007-0524 8007-0525
ST 100E	7008-0296-02	8007-0526 8007-0527

General Information	
Introduction.....	2
Power Source Requirements.....	2
Temperature Specifications.....	2
EOS/ESD Specifications.....	2
Power Supply Features.....	3
Safety	
Safety Guidelines.....	4
System Set-Up	
Tip & Tool Stand Mounting Option (PS-90 & TT-65).....	4
Handpiece Connection.....	4
System Power Up.....	5
Operation	5
LED Operation.....	5
LCD Display.....	5
Temperature Setback & Auto-Off Modes.....	6
Customizing Your System	7
Introduction.....	7
Entering Set-Up Mode.....	7
Password.....	7
Temperature Scale.....	7
Temperature Limits.....	7
Temperature Setback.....	8
Auto Off.....	8
Scan Mode.....	8
Scan Mode Timer.....	8
Back Light Adjustment.....	8
Exiting Set-Up Mode.....	9
Default Factory Settings.....	9
System Calibration & Greeting	10
Corrective Maintenance	11
Spare Parts	11
Service	11
PACE LIMITED WARRANTY STATEMENT	12

General Information

Introduction

Thank you for purchasing an ST 100 system featuring **IntelliHeat™**. This manual will provide you with the information necessary to properly set up, operate, and maintain your system. Please read this manual thoroughly before using the system. IntelliHeat™ is the combination of THC (Tip Heater Cartridge) and SensaTemp handpieces into one system. The system recognizes either handpiece individually and automatically adjusts the menu driving controls for each handpiece. The 230 VAC version system bears the CE Conformity Marking, which assures the user that it conforms to EMC 89/336/EEC. All models featured in this manual are lead free compatible and comply with RoHS and WEEE directives.

Power Source Requirements

Domestic Model		Export Model	
ST 100	Operates on 97-127 VAC, 50/60Hz, 90 Watts maximum at 115 VAC, 60Hz	ST 100E	Operates on 197-253 VAC 50/60Hz, 90 Watts maximum at 230 VAC, 50Hz

Temperature Specifications (All Models)

Tip Heater Cartridge Handpiece Tip Temperature Range: 205 to 455°C (400 to 850°F) nominal.

SensaTemp Handpieces Tip Temperature Range: 37 to 482°C (100 to 900°F) nominal.

Digital Display Resolution: ±5° (°C or °F)

Tip Temperature Stability: ±1.1°C (2°F) at Idle from Set Tip Temperature.

Temperature Accuracy: Meets or exceeds ANSI JSTD 001

EOS/ESD Specifications (All Models)

Tip-To-Ground Resistance: Less than 2 ohms.

AC Leakage: Less than 2 millivolts RMS from 50Hz to 100MHz.

Transient Level: Less than 500mV peak, out to 100MHz.

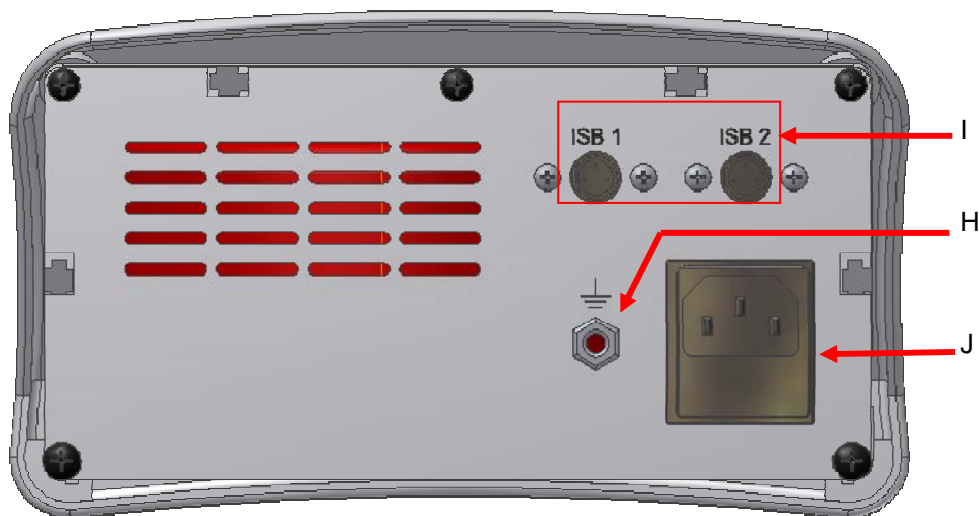
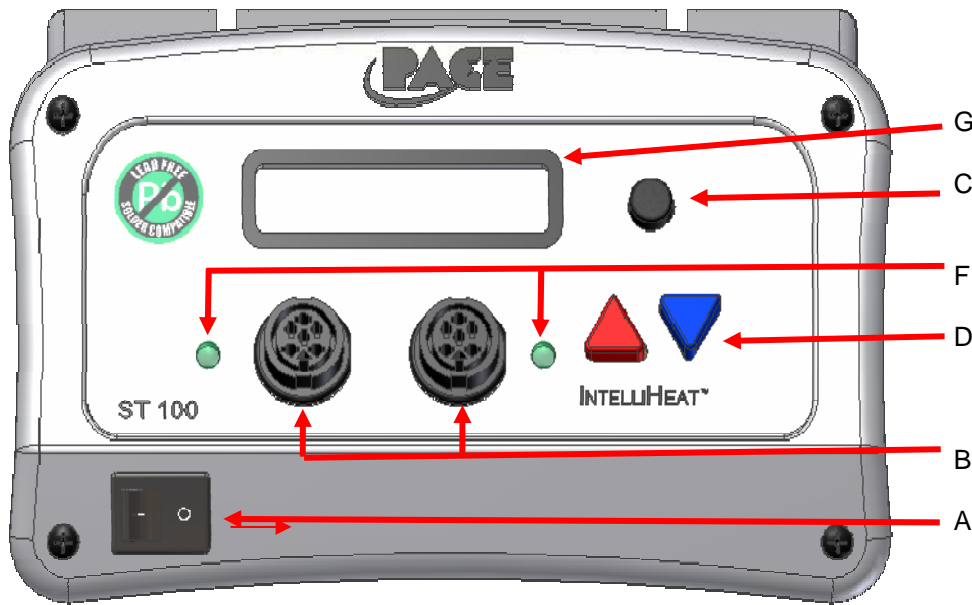

	Feature	Description
A	Power switch	On /off control of power supply.
B	Handpiece Receptacle	Front panel connection of handpiece.
C	Program button	For access and confirmation of program menu functions.
D	Up arrow button	Increase set temperature and scroll through program menu functions.
E	Down arrow button	Decrease set temperature and scroll through program menu functions.
F	Digital control LCD	Indicates status of power supply.
G	Digital display	Displays temperature setting and menu functions.
H	Ground jack	For ground system to static safe work area.
I	ISB connections	Connection for Instant Set Back cubby.
J	Power inlet with fuse	Connection for IEC power cord and fuse replacement.

Safety Guidelines

The following are safety precautions that personnel must understand and follow when using or servicing this product.

1. **POTENTIAL SHOCK HAZARD** - Repair procedures on PACE products should be performed by Qualified Service Personnel only. Line voltage parts may be exposed when the equipment is disassembled. Service personnel must avoid contact with these parts when troubleshooting the product.
2. All handpiece heaters and installed tips are hot when the handpiece is powered on and for a period of time after power off. **DO NOT** touch either the heater or the tip. Severe burns may result.
3. PACE Tip & Tool Stands and handpiece cubbies are designed specifically for use with the associated handpiece and houses it in a manner that protects the user from accidental burns. Always store the handpiece in its holder. Be sure to place the handpiece in its holder after use and allow heater / tip to cool before storing.
4. Always use PACE systems in a well ventilated area. A fume extraction system such as those available from PACE are highly recommended to protect personnel from solder & flux fumes.
5. Exercise proper precautions when using chemicals (e.g., solder paste). Refer to the Material Safety Data Sheet (MSDS) supplied with each chemical and adhere to all safety precautions recommended by the manufacturer.

System Set-Up

Set up the IntelliHeat™ system using the following steps.

1. Store the shipping container in a convenient location. Reuse of these containers will prevent damage if you store or ship your system.
2. Place the Power Switch in the "OFF" or "0" position.

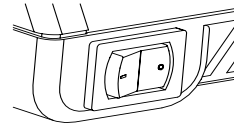

Mounting Options

1. The power supply should be placed directly on a STABLE workbench or work surface.

Tip & Tool Stand Mounting Option (For PS-90, and TT-65)

Some Tip & Tool Stands can be mounted to the power source. To attach the stand to the power source:

1. Insert the 2 large hex head Mounting Screws (head first) into the "T" slot on the side of the power source case as shown.
2. Place the Tip & Tool Stand beside the power source. Insert ends of the 2 Mounting Screws into the 2 Tip & Tool Stand mounting holes as shown.
3. Install a Thumb Nut onto the end of each Mounting Screw and tighten Thumb Nuts.
4. Place the handpiece into its Tip & Tool Stand.

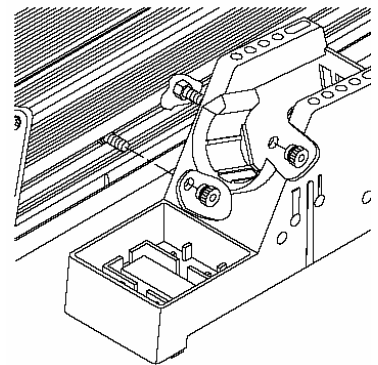

Handpiece Connection - Connect the handpiece connector plug into the Power Receptacle in the following manner.

1. Align guide on connector with slot on power receptacle.
2. Insert connector into power receptacle.
3. Turn the connector housing clockwise to lock in place.

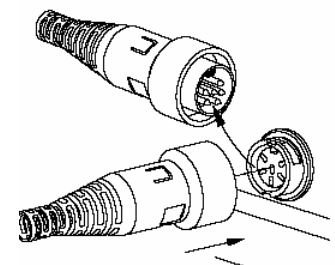

NOTE

IntelliHeat systems are designed for use with PACE handpieces with blue power connectors. Existing, older "black" connector handpieces can be used by purchasing the optional adapter (P/N 6993-0278-P1).

System Power Up

1. Insert the female end of the power cord into the AC Power Receptacle on the rear panel of the power source.
2. Plug the prong end (male end) of the power cord into an appropriate 3 wire grounded AC supply receptacle.

Operation

1. Ensure that the Set-Up procedure has been performed. Check for the following:
 - a) Handpiece(s) connected to the power source.
 - b) Proper tip installed in handpiece(s).
 - c) Power cord connection between an appropriate AC supply and the power source.
2. Turn the Power Switch On ("I"). The handpiece(s) will begin to heat up.
3. To change the set temperature, press the Up (▲) Key or Down (▼) key. The Set Temperature for Channel 1 will be displayed.

NOTE: If a Password has been previously programmed into the system, you will be prompted to enter the password. The operator must enter the correct Password before being allowed to adjust the temperature.

4. Adjust the temperature by pressing and holding the Up (▲) Key or Down (▼) key. The Set Temperature increases first in increments of 1° and then in increments of 10°. When the desired temperature is reached, release the key. Press the round program key to advance to Channel 2 Set Temperature mode and repeat the adjustment using the up and down keys. The system will redisplay the actual temperature(s) in 5 seconds.

NOTE: The Set Temperature can only be adjusted within the defined operating temperature limits. If the upper limit has been reached, the display stop advancing, if the lower limit is reached, the display will read "OFF". Temperature limits can be adjusted in the Set-Up menu. See "customizing your system" section.

5. A temperature offset (65 °C, 150 °F MAX) may be entered when using very large tips. To enter an offset for channel 1, press the program key while the system is in normal operation mode and enter the offset using the up and down keys. To enter an offset for Channel 2, press the round program key again and enter the offset using the up and down keys. The display will return to normal display mode in 5 seconds.

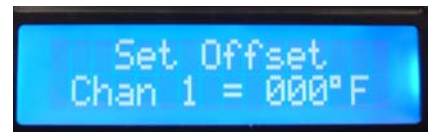

LED Operation

The colored LED on the power source front panel indicates the channel status.

LED Full On Red – A fault has occurred. Check handpiece and/or tip heater cartridge. Check handpiece connection to front panel.

LED Full On Green – The handpiece is at temperature and is ready to be used.

LED Full On Amber – Power is being applied to the heater.

LED Blink Amber – Handpiece channel is in setback or Instant Setback

LED Off - Unit is in Auto-Off mode.

LCD Display

The LCD Display provides two rows of text, up to 16 characters each. The LCD Display will show:

1. The software version of the installed microprocessor (e.g., "Version 1.2") on initial power up.

- The actual and set temperature of the connected handpiece during normal operation. Two display modes are available, Normal Mode and Scan Mode.

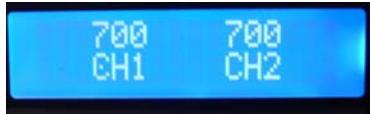
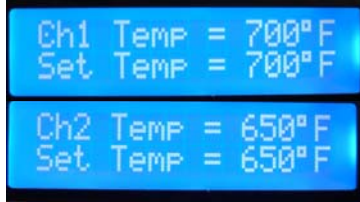
Normal Display Mode	Scan Display Mode
	
Actual Temperature of both channels simultaneously.	LCD changes between Displaying Set and Actual Temperature Information for Channel 1 and Channel 2

- System status, Temperature Setback (SBK), Instant Setback (ISB), & Auto Off (OFF).
- Error messages ("OSE", "SSE" or "OCE") if a system fault is detected. Refer to the "Corrective Maintenance" portion of this manual.

Temperature Setback & Auto-Off Features

Setback Mode

To preserve tip life and save energy, the ST 100 can be programmed to automatically "set-back" the Tip Temperature to 177°C (350°F) after a selected period of handpiece inactivity (adjustable 10-90 minutes in the program menu). As received from the factory, this feature is enabled. To exit

Auto-Off Mode

When enabled, the Auto Off safety system of the ST 100 turns off the power to the handpiece 10-90 minutes after entering Temperature Setback. When the system has entered Temperature Setback, an Auto Off timer within the system circuitry will start running. As received from the factory, this feature is enabled.

Period of Inactivity Begins ↓	System Sets back ↓	System shuts down ↓
Normal Operation	SetBack set to 30 Mins	Auto-Off set to 30 Mins
System operating normally at set temperature.	After 30 mins of inactivity, set temp reduced to 177°C (350 °F) System can be restored to normal operation by pressing the up key or cycling the power switch.	After 30 mins of Setback, the system will shut down. System can be restored to normal operation by pressing the up key or cycling the power switch.

When a channel is in Setback (SBK or SB on display) or Auto-Off (SDN or SD on display) press the up key and the menu to the right will appear, indicating the channel is in SBK or SDN. Simply press the up or down key to return the channel to normal operating mode and the timer will be reset. When exiting Setback or Auto-Off, the Set Temperature and Tip Offset value(s) (if enabled) will be restored. For optimum performance, do not attempt to use the attached handpiece until the Set Tip Temperature is achieved (Green LED).

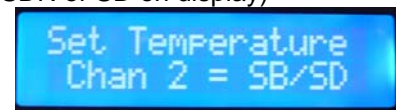

Customizing Your System

Introduction - The menu driven LCD Display of the ST 100 system allows you to easily customize your system. In Set-Up Mode, you can:

- Enter, remove or change a Password.
- Set the Default Temperature scale to °F or °C.
- Change the Upper and Lower Temperature limits for each channel.
- Enable or disable the Temperature Setback feature and adjust the time-out period (if enabled).
- Enable or disable the Auto Off feature and adjust the time-out period (if enabled).
- Enable or disable Scan Mode
- Set Scan Mode Time
- Enter Adjust the back light on the display

Entering the Set-Up Menu

The following instructions should be performed to familiarize the operator with the system.

1. Place Power Switch in the "OFF" ("0") position.
2. Press and hold the Program Key (Ⓢ) while turning on the Power Switch ("1" position).

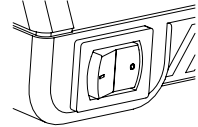

Password

3. The LCD Display will display the version of the system software and change to "Password Needed".
 - a) Press the round key to keep the same password, the up key to enter a password, and the down key to move to the next menu item. If a Password has already been entered, the operator will be prompted to enter it to access the menu. If this occurs, enter the correct Password.
 - b) The password is a 4 digit number between 0000 and 9999. If you enter a password, do not forget what it is.
 - c) Press and release the Program Key to proceed to the next step after entering the password

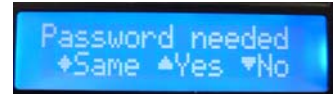

Temperature Scale

4. The LCD Display now shows the stored default Temperature Scale (°C or °F)
 - a) Press the Program Key (Ⓢ) to keep the stored default Temperature Scale or use the up key to change the default Temperature Scale.
 - b) Press and release the Program Key to proceed to the next step



Temperature Limits – To enhance your process control measures, a temperature range can be defined that the operator can freely adjust within (i.e. between 675 °F and 725 °F) or a specific temperature can be locked by setting the upper and lower limit to the same value.

5. The LCD Display now shows the stored default upper temperature Limit for Channel 1.
 - a) Press and release the Program Key (Ⓢ) to keep the stored upper Temperature Limit or adjust the stored upper Temperature Limit using the keypad
 - b) Press and release the Program Key to proceed to the next step.
 - c) The next step is setting the upper limit for Channel 2, follow the same procedure (a and b)

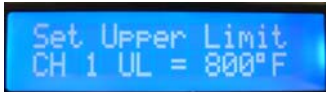

6. The LCD Display now shows the stored default lower temperature Limit for Channel 1.
 - a) Press and release the Program Key (Ⓞ) to keep the stored lower Temperature Limit or adjust the stored lower Temperature Limit using the keypad
 - b) Press and release the Program Key to proceed to the next step.
 - c) The next step is setting the lower limit for Channel 2, follow the same procedure (a and b)

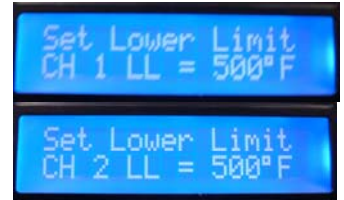

Temperature Setback

7. The LCD Display now shows the stored Temperature Setback time. Time is shown in minutes and can be set for any number between 10 and 90 minutes.
 - a) Press and release the Program Key (Ⓞ) to keep the currently stored Temperature Setback time or adjust the stored Temperature Setback value using keypad. To disable the Setback feature, set the timer to zero.
 - b) Press and release the Program Key to proceed to the next step.



Auto Off

8. The LCD Display now shows the stored Auto-Off time. Time is shown in minutes and can be set for any number between 10 and 90 minutes.
 - a) Press and release the Program Key (Ⓞ) to keep the currently stored Auto Off time or adjust the Auto Off value using the keypad. To disable the Auto-Off feature, set the timer to zero.
 - b) Press and release the Program Key to proceed to the next step.

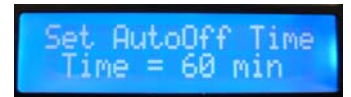

Scan Mode

9. The LCD Display now shows the Scan mode option. Scan mode displays the set and actual temperatures for Channel 1, and then changes to the set and actual temperature for Channel 2 after a defined period of time (defined in the next step).
 - a) Press and release the Program Key (Ⓞ) to keep the current setting for Scan mode or use the up key to enable/disable Scan mode.
 - b) Press and release the Program Key to proceed to the next step.

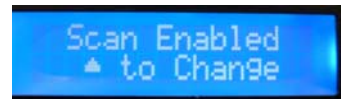

Scan Mode Timer

10. The LCD Display now shows the Scan mode timer option. The timer can be set for any number of seconds between 1 and 999. This is the amount of time the display will show Channel 1 information before changing to Channel 2 information as described above. This will repeat every 5 seconds in the example.
 - a) Press and release the Program Key (Ⓞ) to keep the current setting for Scan timer mode or use the up or down key to select setting
 - b) Press and release the Program Key to proceed to the next step.

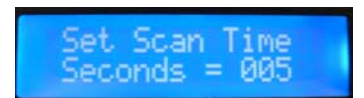

Back Light

11. The LCD Display now shows the Backlight option. The backlight on the display can be adjusted from 1 (darker) to 99 (brighter).

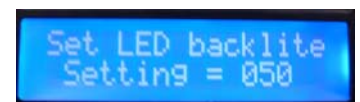

- a) Press and release the Program Key (Ⓢ) to keep the current setting for Scan mode or use the up or down key to select setting.
- b) Press and release the Program Key to proceed to the next step.

Exiting Set-Up Mode

12. The LCD Display now displays the end of the menu.

- a) Press and release the Scroll Up (▲) Key to exit Set-Up Mode and return to normal operation.
- b) Press and release the Scroll Down (▼) Key to return to the start of the Set-Up Mode procedure. Go back to step 3.



Default Factory Settings

The ST 100 systems come equipped with a number of features, which may be adjusted by the user. Listed below are the features and default settings of each. To change and/or learn about any of these features, refer to the applicable part of the "Customizing Your System" section of this manual.

Feature	Factory Setting
Password	None Entered
Default Temperature Scale (°C/°F)	°F for 115 VAC Systems
	°C for 230 VAC Systems
Upper Temperature Limit	454 °C (850 °F)
Lower Temperature Limit	204 °C (400 °F)
Set Temperature	"OFF"
Tip Offset Constant	"0"
Temperature Setback	Enabled, 30 minutes
Auto Off	Enabled, 60 minutes
Scan Mode	Disabled
Scan Mode Timer	3 Seconds

System Calibration

All systems are tested for temperature accuracy at the factory and can be checked for calibration according to requirements. No internal adjustments can be made to the power supply. SensaTemp based technology handpieces (PS-90 & TT-65) do not need to be calibrated as they feature a laser trimmed, platinum RTD sensor. However, Tip Heater Cartridge Handpieces (TD-100 and MT-100) can be calibrated in the following manner.

1. Install a tip with an embedded thermocouple into the handpiece connected to the system. Tips with K type thermocouples welded to them are available from PACE.
2. Connect the thermocouple assembly to a compatible k-type thermo couple meter, PACE's Tip Temperature Monitor (P/N 8001-0087-P1) or PACE's PM 200 (P/N 8007-0464-P1).
3. Turn on system and allow the tip to stabilize at the set temperature.
4. Record measured temperature on monitor.
5. Turn off power source and turn it back on while holding down the program (round) key and the up key.
6. The system will ask you if you want to enter a calibration for channel 1. If yes, press the up key, if no press the down key.
7. If you pressed the up key, you will be prompted to enter the measured temperature from step 4 using the key pad. Once entered, press the round key and you will be prompted to calibrate Channel 2 in the same manner.
8. Press the program key and the system will restart.
9. To clear the calibration, remove the handpiece while the power source is ON.
10. When a channel has NOT been calibrated the "C" in channel will display a dot in the center of the "C". See image below, Channel one has not been calibrated, Channel 2 has been calibrated. The "calibration" indicator will appear in Scan and normal display modes. Additionally, **NO dot** will appear when a SensaTemp handpiece has been connected to the system as it does not require calibration.

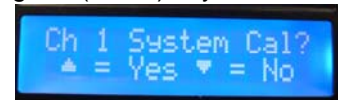

Entering a Greeting

The ST 100 can be programmed to enter a greeting when the system is turned on.

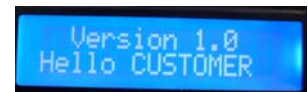

To enter the greeting message, turn off the power, hold down the program (round) key and the down key and turn on the unit. You will be asked if you want to input a hello message. Press the up key for "yes", and the down key for "no".



If you pressed "yes" the screen will change to the input screen where you can enter up to 10 characters or symbols using the up and down keys. When finished, press the program key.

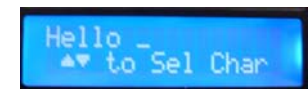

If a message has already been entered, you will see this message when you power the system on while holding down the down and program key. Press up for "yes" and down for "no". To keep the existing greeting, press the down key, to delete it and enter a new one of just delete it, press the up key

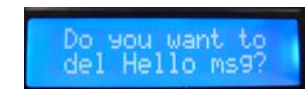

Corrective Maintenance

Digital Display Message Codes

Listed below are message codes, which, may be shown on the LED Display if a mistake were to be made by the operator (e.g., wrong Password entry) or if the system has malfunctioned.

LED Display Message	Description
OSE	"Open Sensor Error" No handpiece is connected to the power receptacle. Correct by connecting handpiece
	The sensor in the heater or tip cartridge has failed. Correct by replacing the heater or tip cartridge.
SSE	"Shorted Sensor Error" The handpiece heater assembly sensor is shorted. Refer to the appropriate handpiece manual.
OCE	"Over Current Error" The handpiece heater assembly may be defective. Refer to the appropriate handpiece manual Contact PACE or your authorized local representative for assistance.

Power Source

Symptom	Probable Cause	Solution
No power to system	Blown Fuse	Replace the fuse (located in the AC Receptacle Fuse Holder) with one of the same rated value (see Table 4, Spare Parts). The unit comes with one spare fuse in the AC receptacle
Handpiece will not heat	Defective Heater	Refer to the appropriate handpiece manual
	Power Source Malfunction	Contact PACE

Spare Parts

Item #	Description	PACE Part Number
1	Fuse, 1.0 Amp Time Lag	1159-0275-01-P5
	Fuse, 0.5 Amp Time Lag (Export Models)	1159-0275-02-P5
2	Replacement PCB	6020-0211-P1

Service

Please contact PACE or your local distributor for service and repair.

PACE LIMITED WARRANTY STATEMENT

Limited Warranty

Seller warrants to the first user that products manufactured by it and supplied hereunder are free of defects in materials and workmanship for a period of one (1) from the date of receipt by such user. This Warranty as applied to blowers and motor pumps is limited to a period of six (6) months. Other brand equipment supplied but not manufactured by PACE are covered under their respective manufacturer's warranty in lieu of this Warranty.

This warranty does not cover wear and tear under normal use, repair or replacement required as a result of misuse, improper application, mishandling or improper storage. Consumable items such as tips, heaters, filters, etc. which wear out under normal use are excluded. Failure to perform recommended routine maintenance, alterations or repairs made other than in accordance with Seller's directions, or removal or alteration of identification markings in any way will void this warranty. This warranty is available only to the first user, but the exclusions and limitations herein apply to all persons and entities. SELLER MAKES NO OTHER WARRANTY, EXPRESS OR IMPLIED, AND MAKES NO WARRANTY OF MERCHANTABILITY OR FITNESS FOR A PARTICULAR PURPOSE.

Seller will, at its option, repair or replace any defective products at its facility or other location approved by it at no charge to user, or provide parts without charge for installation by the user in the field at user's expense and risk. User will be responsible for all costs of shipping equipment to Seller or other location for warranty service.

EXCEPT FOR THE REMEDY ABOVE DESCRIBED, UNLESS OTHERWISE REQUIRED BY APPLICABLE LAW, SELLER WILL HAVE NO OTHER OBLIGATION WITH REGARD TO ANY BREACH OF WARRANTY OR OTHER CLAIM WITH RESPECT TO THE PRODUCTS, OR LIABILITY FOR ANY DIRECT, INDIRECT, CONSEQUENTIAL, OR INCIDENTAL LOSS OR DAMAGE CAUSED BY OR OCCURRING IN CONNECTION WITH ANY OF THE PRODUCTS.

Warranty service may be obtained by contacting the appropriate PACE Company or local Authorized PACE distributor as set forth below to determine if return of any item is required, or if repairs can be made by the user in the field. Any warranty or other claim with respect to the products must be made with sufficient evidence of purchase and date of receipt, otherwise user's rights under this warranty shall be deemed waived.

For PACE USA Customers:

PACE, INCORPORATED
9030 Junction Drive
Annapolis Junction, Maryland 20701
Tel. 301-317-3588
FAX. 301-498-3252

For PACE EUROPE Customers:

PACE EUROPE LIMITED
13 Tanners Drive, Blakelands
Milton Keynes
MK1 45BU
United Kingdom
Tel. (44) 1908 277666
WARRANTY SERVICE FAX: (44) 1908 277 777

All other Customers:
Local Authorized PACE Distributor